

Technical Data Specifications

MX-100 Reload Housing

(873-02) (873-03) (873-04) (873-05) (873-06) (872-94) (873-85)
(872-94) (872-95) (873-56) (873-57) (873-58) (873-83) (873-86) (873-84)

Housing Technical Data

Données Techniques relatives aux De MX 100 Gains

Technische Daten MX 100 Gehäuse

Especificaciones de Datos Técnicos Coraza MX 100

For use with:
Pour utilisation avec:
Für gebrauch mit:
Usado en:

DU 404:
(888-46)
(888-20)
(888-17)
(888-07)
(888-12)

The logo for DUNLEE, featuring the word "DUNLEE" in a bold, blue, sans-serif font. The letters are underlined with a thick blue line.

-TABLE OF CONTENTS -TABLE DES MATIÈRES -INHALTSVERZEICHNIS -CONTENIDO

Product Specifications, Caractéristiques De Produit, Produktbeschreibungen, Especificaciones De Producto	3
Thermal Characteristics, Echauffement Et Refroidissement. Thermische Eigenschaften Característica térmicas	4
Stator Drawing, Plan du stator, StatorBewegungsZeichnung, Gráfica del Motor	4
Dimensional Data, Dimensionnement, Abmessungen, Información de las Dimensiones	5
Contact Information, L'Information De Contact, Kontakt-Informationen Información Del Contacto	6



Please refer to accompanying General Information Booklet for important safety warnings, servicing and operating conditions, warranty, and return procedure.

Veillez se référer à accompagner le Livret d'Informations Générales pour des avertissements importants de sûreté, à l'entretien et aux conditions de fonctionnement, à la garantie, et au procédé de retour.

Beziehen Sie bitte sich das Begleiten des allgemeinen Informationsheftes für wichtige Sicherheit Warnungen, die Wartung und die Betriebsbedingungen, Garantie und auf Rückholverfahren.

Refiera por favor a acompañar el Librete de la Información General para las advertencias importantes de seguridad, a mantenimiento y a las condiciones de funcionamiento, a la garantía, y al procedimiento de vuelta.

- Document originally drafted in English
- Le document a été à l'origine écrit en Anglais
- Dokument wurde ursprünglich auf Englisch geschrieben
- El documento fue escrito originalmente en Inglés

**-PRODUCT SPECIFICATIONS -CARACTÉRISTIQUES DE PRODUIT
-PRODUKTBESCHREIBUNGEN -ESPECIFICACIONES DE PRODUCTO**

Cast Aluminum, Lead Lined Housing Gaine d'Aluminium moulé, interlingé en plomb Gehäuse aus Aluminiumguß mit Bleiauskleidung Coraza de Aluminio Forjado, Revestida de Plomo	
Maximum Voltage Polarity Tension polarisé maximum Maximale Spannungspolarität Polaridad de Voltaje Máximo	150 kVp
High Voltage Cable Connections Câbles de liaisons Haut Tension Hochspannungs-Kabelverbindungen Conexiones del Cable de Alto Voltaje	Federal Standard
Focus to Collimator Flange Distance Distance foyer-bride du diaphragme Abstand Brennfleck Blendenflansch Distancia del foco al colimador	58.7 mm (2.31 inches)
Total Heat Storage Capacity Capacité Calorifique Wärmespeicherfähigkeit Capacidad térmica	296 kJ (400 kHU)
Minimum Inherent Filtration (Al equivalent) Filtration Inhérente Minimale (équivalent Al) Mindesteigenfilter (Al-Gleichwert) Filtración inherente mínima (equivalencia de Al)	1.1 mm Al
Additional Filtration Filtration Additionnelle Zusätzlichefiltration Adicional Filtración	0.5 mm Al *0.5 mm Al filtration added to meet IEC 60601-1-3. Requires tool for removal.
Temperature Range for Transportation Températures limite pour Le Transport Grenztemperaturen für Transport Límite de Temperaturas para Transporte	-10°C + 100°C (15°F + 212°F)
Radiation Leakage Technique Facteur de charge pour Rayonnement de Fuite Hochstbetriebswerte Medida de la protección antirrayos	150 kVp, 4 mA
Stator Resistance Résistance de la stator Widerstand für der stator Resistencia del estator	23 Ω/ 23 Ω
Weight lbs. (kg) Poids (kg) Gewicht (maximale) (kg) Peso (kg)	26.6 kg (58.6 lbs.)
Nominal Continuous Rating Puissance nominale de longue durée Langzeit-Nennleistung Potencia nominal de larga duración	185 W (250 HU/s)
Applicable Standards Normes applicables Anwendbare Standards Estándares aplicables	IEC 60336, IEC 60522, IEC 60526, IEC 60613, IEC 60678, EN 60601-1, EN 60601-1-3, EN 60601-2-28

-THERMAL CHARACTERISTICS -ECHAUFFEMENT ET REFROIDISSEMENT
-THERMISCHE EIGENSCHAFTEN -CARACTERISTICA TÉRMICAS

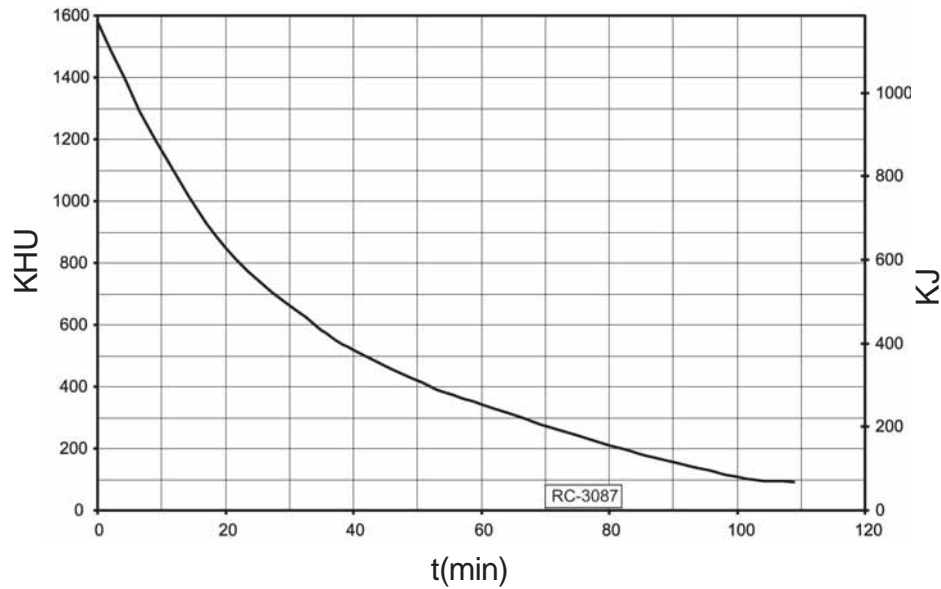

-STATOR DRAWING -PLAN DU STATOR -STATORBEWEGUNGSZEICHNUNG -GRÁPHICA DEL MOTOR

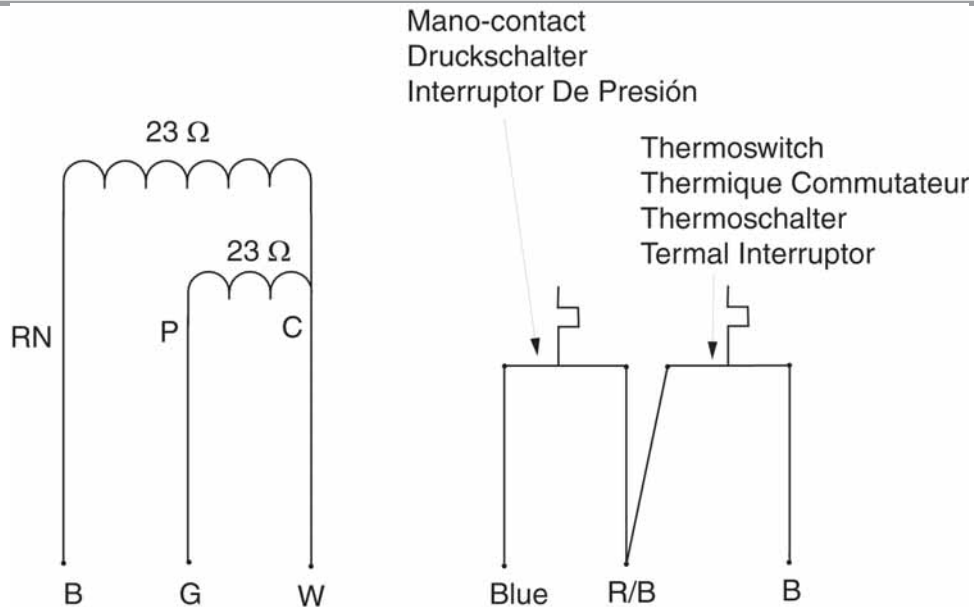

R	W	G	P	RN	B	Y	BLUE	C
- Red	- White	- Green	- Phase	- Run	- Black	- Yellow	- Blue	- Common
- Rouge	- Blanc	- Vert	- Phase	- Exécuteur	- Noir	- Jaune	- Bleu	- Neutre
- Rot	- Weiß	- Grün	- Phase	- Laufen	- Schwarzes	- Gelb	- Blau	- Neutrales
- Rojo	- Blanco	- Verde	- Fase	- Se ejecutan	- Negro	- Amarillo	- Azul	- Neutral

-DIMENSIONAL DATA -DIMENSIONNEMENT -ABMESSUNGEN -INFORMACIÓN DE LAS DIMENSIONES

MX-100-180°

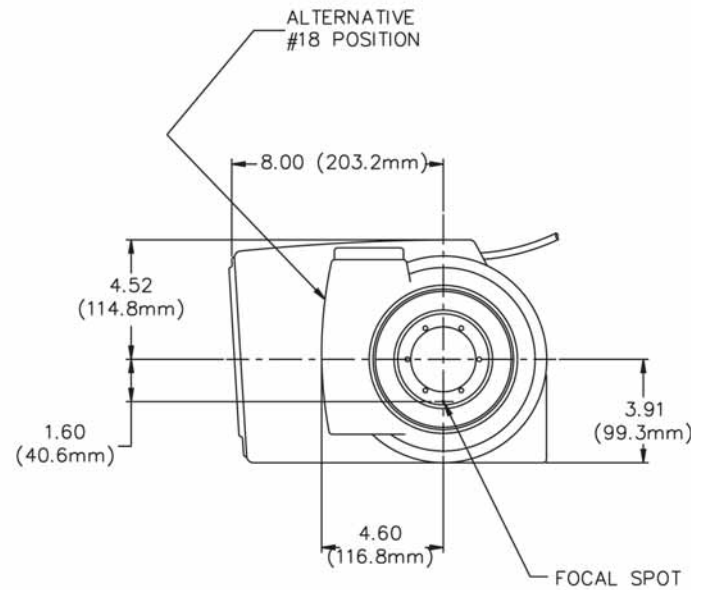
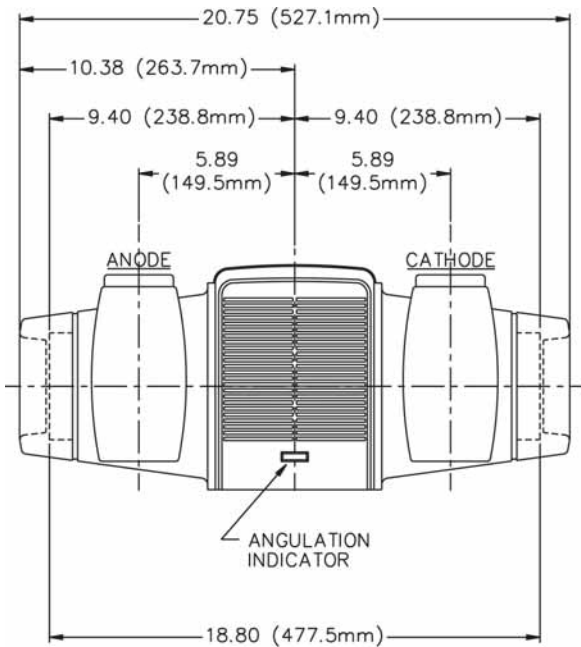

MX-100-90°

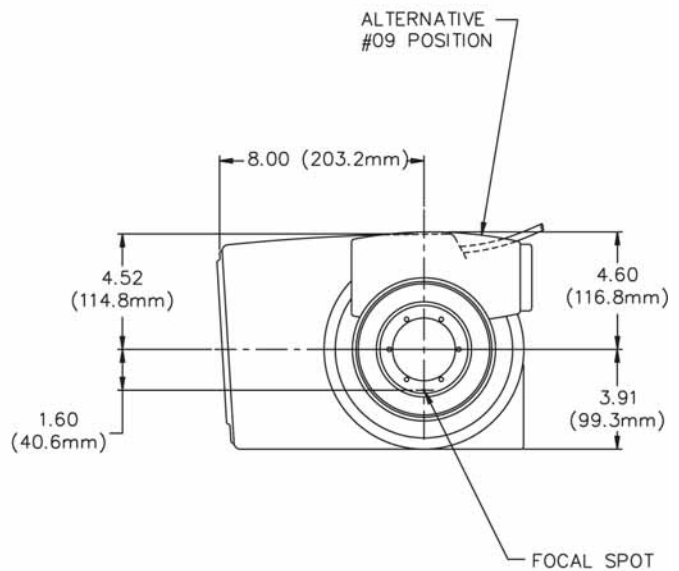
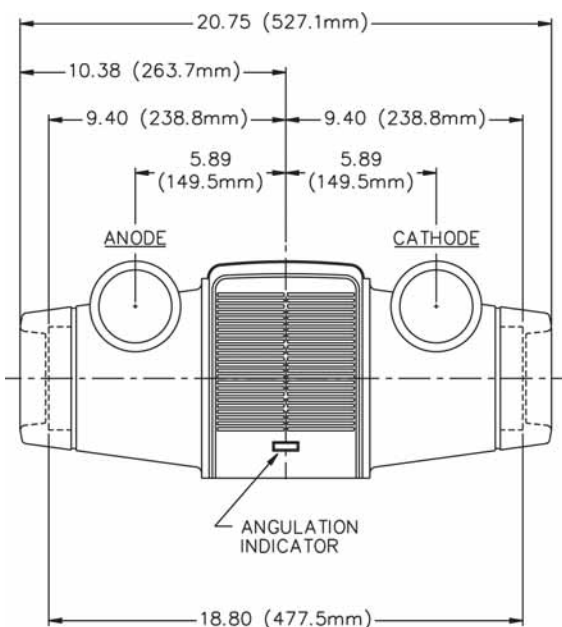

Sales, Service, and Manufacturing Locations

World Headquarters

555 North Commerce Street
Aurora, Illinois 60504 USA
Tel: 800.238.3780 (U.S. & Canada)
630.585.2100
Fax: 630.585.2125

Tubemaster Facility

2312 Avenue J
Arlington, Texas 76006 USA
Tel: 800.544.9729 (U.S. & Canada)
817.640.7666
Fax: 817.640.6644

Medical Components

Sales and Service Office - Germany
Marbacher Strasse 114
D-40597 Düsseldorf, Germany
Tel: 49.0.211.20.30.05
Fax: 49.0.211.20.30.00

Richmond Facility

8819 Whitepine Road
Richmond, Virginia 23237 USA
Tel: 800.526.0555 (U.S. & Canada)
804.714.2501
Fax: 804.714.2507

Sales Office - Mexico

La Palma 6, 3rd Floor
Col. San Fernando La Herradura
Huixquilucan, Edo. Mex., México.
CP 52736
Tel: 52.55.52.69.92.03
52.55.21.09.75.21
Fax: 52.55.52.69.92.04

Sales Office - Europe

Philips Medical Systems S.p.A
Via Casati 23
20052 Monza (MI) Italy
Tel: 39.039.203.6536
Fax: 39.039.203.6175

Sales Office - Asia

26th, Hopewell Center
17 Kennedy Road, Wanchai
Hong Kong
Tel: 852.2876.7569
Fax: 852.2527.7136

Sales Office - Brazil

Rua Ceará, 58 Alphaville
0646-120 Barueri-SP-Brazil
Tel: 55.11.4689.6026
Fax: 55.11.4189.0288

Sales Office - France

102 Bis rue de la Ferté Alais
91820 Boutigny sur Essonne, France
Tel: 33.1.6990.7233
Fax: 33.1.6990.7233

European Union Representative

Philips Medical Systems
Dept.: Corporate Quality & Regulatory
Veenpluis 4
5684 PC Best
The Netherlands



Visit us at www.dunlee.com